



## A Study on the Mechanism of the Influence of Cultural Traits of Private Universities on the Innovative Behavior of Teaching Staff

Xu Shuyan<sup>1</sup>, Xu WenZe<sup>2\*</sup>

### ARTICLE INFO

#### Article History:

Received: 04 January 2024

Received in Revised Form: 10 February 2024

Accepted: 15 February 2024

DOI: 10.14689/ejer.2024.110.10

#### Keywords

Culture, Mission, Work Engagement, Innovative Behaviour, Adaptability, Participation.

### ABSTRACT

**Purpose:** This study focuses on investigating the correlation between cultural factors and innovative work behaviour. Additionally, it aims to explore the potential influence of work engagement as a mediator in this relationship. **Design/ Method/ Approach:** This study utilizes a quantitative research approach with a cross-sectional research design. Information is gathered from participants through the use of surveys. We collected 556 responses that were suitable for analysis in this research. The data is analysed using SPSS, employing CFA and correlation analysis techniques. **Findings:** The result of the study supports the mediating role of work engagement. This research

also supports the direct effect of the cultural factors through dimensions like adaptability and mission. These findings also support the pivot role of participative culture as well. **Practical Implications:** This research provides valuable insights for managers in the education sector, highlighting the significance of culture and its various elements in enhancing employee engagement and fostering innovative work behaviour. **Originality:** The present study stands out as it explores the impact of culture on work engagement by examining various dimensions of both factors. The participants in this study are individuals employed by educational institutions.

© 2024 Ani Publishing Ltd. All Rights Reserved.

## Introduction

Organizations worldwide are encountering various challenges in their quest to enhance performance and competitiveness. One of the key factors for success is innovation, which has the ability to enhance an organization's competitiveness and overall performance. The government organization's characteristics or organizational structure are hierarchical, bureaucratic, and rigid, according to [Khairi \(2022\)](#). Scholars have recently placed a significant emphasis on the factors that can enhance employee innovation at the university level. The studies have explored various factors that can enhance innovation among employees, including individual traits, culture, organizational support, and leadership

<sup>1</sup> International College, Krirk University Thanon Ram Intra Khoang Anusarbari Khet Bang Khen Krung Thep, Maha Nakhon 10220, Thailand., Email: [xsy@mnust.edu.cn](mailto:xsy@mnust.edu.cn)

<sup>2</sup> International College, Krirk University Thanon Ram Intra Khoang Anusarbari Khet Bang Khen Krung Thep, Maha Nakhon 10220, Thailand., Email: [M13929597601@163.com](mailto:M13929597601@163.com)

\*Correspondence: [M13929597601@163.com](mailto:M13929597601@163.com)

styles (Hansen & Pihl-Thingvad, 2017). It is crucial for organizations to foster a culture of innovation among employees to ensure long-term viability. These organizations should consider revising or updating their HR policies in order to enhance their performance in terms of innovation (Yan-mei & Zheng-tang, 2020). Higher education institutes should create a nurturing atmosphere to enhance the employees' innovative potential.

Previous studies have extensively examined the correlation between innovation, work engagement, and organizational support. The innovation behaviour of employees is influenced by the supervisory practices and innovation strategies implemented at the organizational level (Purc & Laguna, 2019). It is crucial to ensure that organisational management practices and strategies are simulated and aligned in order to foster a culture of innovation among employees. Research has explored the intricate connection between work engagement and organizational support, highlighting their crucial role in enhancing the innovation environment within institutes. Various methods can be employed by organizations seeking to enhance innovative behaviour among their employees (Fitriana & Satrya, 2022).

Researchers have also explored the importance of involving employees in meaningful work to foster their intrinsic motivation towards innovation (Pradhan & Jena, 2019). The topic of employee engagement has been extensively explored in various studies within the business context (Afrifa Jr et al., 2022). When employees are engaged in their role performance, they express themselves mentally, emotionally, cognitively, and physically. The individual who is dedicated to their work goes above and beyond to achieve their personal objectives, which in turn will have a positive effect on the goals of the organization. Work engagement plays a crucial role in fostering sustainability within an organization (Khusanova et al., 2021).

In addition, several researchers have examined the various elements that can influence the achievement of the organization. Learning from the organizational environment is an important factor to consider. The organization's failure to adapt and learn from its surroundings can significantly impact its level of success. Hence, the ability to adapt to different cultures is crucial for the survival of educational institutions (Fuad et al., 2022). The organization's thinking process is transformed through a cultural shift that involves employees at all levels of the organization. The organizational culture should be flexible, inclusive, and responsive to the organization's environment. It has a significant and lasting impact on the performance of the organization. At times, organizations encounter challenges when it comes to upholding a consistent cultural message (Badawi & Susilo, 2019). The culture of the organization should be in sync with its strategies, mission, and goals, fostering employee engagement and innovation. Overall, it plays a crucial role in the long-term survival of the organization. The aim of this study is to investigate the correlation between cultural factors and innovative work behavior, with a focus on the role of work engagement as a mediator.

### Literature Review and Hypotheses Building

Cultivating a forward-thinking mindset is crucial for both individual and organizational achievement. In the realm of management literature, the importance of innovative behavior cannot be overstated when it comes to enhancing organizational performance. Academics have defined innovative behavior as intentional and purposeful

behavior that involves the implementation of new ideas within an organization or group to gain advantages in terms of individual, group, or organizational benefits. Previous research has described innovative behavior as the introduction and implementation of new procedures, processes, products, and ideas within an individual's organization, work unit, or work role (Hock-Doepgen et al., 2024). Many employees view innovative work behaviour as an additional role that deserves compensation. These employees also believed that work behaviour should be acknowledged for career advancement (Liu et al., 2019).

The culture within an organization plays a crucial role in shaping the behaviour of its employees. To promote innovation at a higher level, it is necessary to modify cultural and organizational structures (Sriahayu et al., 2023). Developing organizational competitiveness through innovation is crucial. The culture of the organization often embodies qualities such as dynamism, adaptability, creativity, and innovation. Therefore, creativity is fostered by the culture or environment of the organization. The organization's culture of innovation should always seek out new facilities and opportunities in a methodical manner. The innovative behaviour of the employees working in the university is greatly influenced by their own innovative behaviour. This highlights the significance of utilizing this cell culture to foster innovation in the workplace.

A recent study by Yamak and Eyupoglu (2021) highlights the crucial impact of leadership style on fostering proactive innovation behaviour among employees. The findings emphasize the role of leadership as a cultural trait in driving innovation within organizations. This scholar has provided a detailed analysis of the intricate relationship between leadership style, organizational culture, and innovation behaviour. Commitment to the organization, active participation of staff, and collaboration within the workforce are key attributes of a progressive work environment. The group of people at the organization will be more innovative when the organization prioritizes the growth and development of its employees. These individuals prioritize transparency and actively engage in risk-taking activities that benefit the organization in the long run. In a recent study by Siswanti and Nurhariati (2022), the impact of culture on innovative behaviour was empirically examined. These studies collectively affirm the hypothesis:

**H1:** *The culture of private undergraduate universities significantly correlates with the innovative behavior of its employees.*

#### *Cultural Adaptability Characteristics and Innovative Behaviour (H1a)*

Research has shown that cultural characteristics have a positive impact on innovative work behaviour. The adaptability of the culture relies on its ability to respond and be flexible. It fosters an atmosphere that encourages innovation. Research has indicated that embracing cultural change and adopting a supportive approach can enhance innovation in the workplace (Fuad et al., 2022). The culture of the organization fosters a mindset of adaptability and a proactive approach to seeking out resources and opportunities for personal and organizational growth. A study conducted by Zhu and Zhang (2020) emphasized the significance of cultural characteristics in enhancing employees' innovative behaviour.

**H1a:** *The cultural adaptability characteristics of private undergraduate schools have a significant impact on the innovative behaviour of faculty.*

### *Cultural Participation and Innovative Behaviour (H1b)*

The culture of the organization emphasizes collaboration, active involvement, and dedication from employees. Several studies have defined cultural participation as the faculty's involvement in the decision-making process and its impact on behaviour (Alredaisy, 2023). This involvement in the academic culture of the institution. In this particular environment, the emphasis is placed on fostering employee support and identification, which has a positive impact on performance. In this particular culture, employees are strongly encouraged to think outside the box and come up with innovative ideas. They also strive to implement and explore new ideas.

To foster such a culture, it is crucial for organizational leaders to take charge and provide effective coaching to their team members. An open culture will be fostered, encouraging employees to freely exchange their ideas. They will recognize the significance of fostering innovative behaviour within the organization. In this scenario, it is crucial for the leader of the organization to take an active stance and motivate employees to engage in activities that promote employee innovation (Husin et al., 2021). The studies indicate:

**H1b:** *The cultural participation characteristics of private undergraduate schools have a significant impact on the innovative behaviour of faculty.*

### *Cultural Consistency and Innovative Behaviour (H1c)*

Researchers have identified cultural consistency as a shared set of norms and values in the workplace (Gorton & Zentefis, 2020). They have found a strong correlation between innovative work behaviour and cultural consistency. Developing an innovation culture within an organization is a crucial responsibility of the management. For this, a high level of dedication and regularity is expected from the employees. A strong foundation within the organization is fostered by a culture that promotes and nurtures innovation. Experts have highlighted the importance of a strong and unified cultural message within an organization when it comes to fostering innovation. This message can greatly influence how employees approach and engage with innovative practices (Sadegh Sharifirad & Ataei, 2012). Similarly, research has shown that maintaining cultural consistency can greatly enhance an employee's ability to think innovatively. The culture of the university plays a crucial role in fostering innovative behaviour among students and faculty. Thus, the hypothesis states:

**H1c:** *The Cultural Consistency characteristics of private undergraduate schools have a significant impact on the innovative behaviour of faculty.*

### *Cultural Mission and Innovative Behaviour (H1d)*

Mission is crucial in establishing the direction of the organization. The culture of the organization defines how the organizational mission will be accomplished. However, values play a crucial role in shaping the culture of the organization. The culture of the organization often has a significant impact on employee behaviour. The influence of culture often extends to customer interactions. The culture of the organization that prioritizes risk-taking and innovation can greatly influence employees' willingness to take risks. Employees with a strong academic background are more likely to embrace risk and pursue innovative ideas that contribute to the company's growth (Alateeg & Alhammadi, 2024). The cultural mission of universities has a profound influence on fostering innovative

behaviour. A strong and clear mission that emphasizes growth and innovation will motivate the faculty to work towards these goals (Villarroya, 2017). Researchers also propose that the vision promoted by the organization is crucial. Being engaged in innovative behaviour is a highly motivating factor. A study conducted by Zhu et al. (2020) highlighted the positive impact of leadership that is dedicated to promoting innovation on the overall organizational climate. Therefore, the hypothesis is:

**H1d:** *The cultural mission characteristics of private undergraduate schools have a significant impact on the innovative behaviour of faculty.*

### *Impact of Cultural Characteristics on Work Engagement (H2)*

A culture that emphasizes the sense of community being integral and valued in the organization can have a significant impact on organizational engagement. According to Radu (2023), the workplace can undergo a transformation into an organization where individuals are dedicated and interconnected. The cultural aspects of the university have a significant impact on the level of employee engagement. Put simply, it has a significant impact on the work engagement of faculty members. Previous research conducted by Singh (2019) demonstrated that when academic institutions foster a culture that values, acknowledges, and supports their faculty members, it leads to enhanced work engagement among these employees. It is widely understood that a positive work culture is built upon common values, transparent communication, and encouraging leadership. With the presence of these factors, employee productivity and engagement experience improvement (Afrifa Jr et al., 2022). Additionally, the leadership style is a crucial element of culture. This factor also influences the behaviour of the employees and enhances their work engagement. A study conducted by Yu et al. (2023) delves into the intricate connection between organizational culture and engagement, yielding similar findings. Thus, it can be hypothesized:

**H2:** *There is a significant correlation between the cultural characteristics of private undergraduate universities and the work engagement of faculty.*

### *Participatory Characteristics and Work Engagement (H2a)*

The organization's strong culture consistently adjusts to environmental changes. This culture places a strong emphasis on the value of individuals and prioritizes growth and adaptability in response to the surrounding environment. According to research conducted by scholars, employees who actively participate in organizational activities tend to be more engaged with the organization (Beidokhti et al., 2016). Likewise, the faculty members at the higher education institute are thought to have a positive impact on employee engagement. The study conducted by Yoerger et al. (2015) revealed a significant correlation between employee participation and employee engagement, indicating a positive impact. Therefore, the hypothesis posits:

**H2a:** *The cultural participation characteristics of private undergraduate school culture have a significant impact on work engagement.*

### *Adaptive Characteristics and Work Engagement (H2b)*

The concept of adaptability has been extensively explored in academic literature, particularly in relation to how it is influenced by cultural environments. An adaptable

working environment prioritizes the interaction between individuals and their surroundings, leading to increased adaptability (Yang et al., 2019). Likewise, the dedication of employees in academic institutions is closely tied to their work due to the influence of the organizational culture. The tone of flexibility is established by the organization. Adapting organizational teams to meet the demands of assigned tasks is crucial for the success of the organization. A recent study conducted by Zhang and Wang (2022) found that the factor of organizational adaptability has a significant influence on work engagement. Another study conducted by Gabel-Shemueli et al. (2019) found that work engagement is positively influenced by cultural adaptability. Therefore, the hypothesis asserts:

**H2b:** *The cultural adaptive characteristics of private undergraduate school culture have a significant impact on work engagement.*

#### *Consistency Characteristics and Work Engagement (H2c)*

Cultural consistency is the practice of maintaining and aligning principles, beliefs, and shared values within an organization. Behavioural consistency is crucial for employees to meet the expectations and norms of the culture (Chatman & O'Reilly, 2016). It is the responsibility of the organization's leaders to maintain a consistent culture that aligns with the organization's identity. Likewise, maintaining a consistent cultural environment has a notable impact on work engagement. The study conducted by Siswanto (2023) revealed a significant correlation between the consistency of culture and work engagement, indicating a positive impact. Hence, the hypothesis formulated is:

**H2c:** *The cultural consistency characteristics of private undergraduate school culture have a significant impact on work engagement.*

#### *Mission and Work Engagement (H2d)*

Culture of the organization also includes recognition processes, rewards, shared beliefs, mission and vision. A culture that is mission driven shows that employees working there are more passionate regarding the mission of their organization (Warrick, 2017). The employees who are working at the mission driven organizations are mostly inspired by their job description. They like the people with which they work with. There is a significant correlation between the work engagement of faculty members and the mission of the organization. The work engagement of the employees will be improved by the clearly stated mission statement. Research In a study conducted by Warrick (2017), the significance of organizational mission in enhancing work engagement was highlighted. The study found that the mission of the organization has a significant impact on work engagement. Therefore, the hypothesis suggests:

**H2d:** *The cultural mission characteristics of private undergraduate school culture have a significant impact on work engagement.*

#### *Relationship between Work Engagement and Innovative Behaviour (H3)*

The behaviour of the employees is enhanced by the various motivational conditions. Work engagement plays a crucial role in motivating employees to exhibit innovative work behaviour. An employee who is deeply committed to the organization will always experience a sense of purpose and ownership in their work. Consequently, they are

motivated to go above and beyond, and undertake various initiatives that contribute to the organization's success. If a company fails to effectively engage its employees, it will hinder their ability to innovate and erode their confidence. In academic settings, there is a clear connection between the level of engagement of faculty members and their ability to engage in innovative work (Viitala et al., 2023). The research has emphasized the connection between work engagement and innovative work behavior. In addition, the study conducted by Vithayaporn and Ashton (2019) highlighted the role of work engagement in driving the innovative work behaviour of faculty members. In a similar vein, the study conducted by Ramadhani et al. (2022) also yielded comparable results.

**H3:** *There is a significant relationship between faculty work engagement and their innovative behaviour.*

#### *Dedication and Innovative Behaviour (H3a)*

Literature is often described as an engaging and fulfilling intellectual pursuit that reflects dedication and enthusiasm. Employee engagement refers to the extent to which individuals are committed and dedicated to their work (Khalid et al., 2021). The dedication of university employees is fundamental to work engagement. It has a significant impact on fostering innovation behaviour among employees. Hansen et al. (2017) found that a leadership style that promotes work engagement can foster innovative behavior in employees. The study conducted by Kananu et al. (2020) found a positive relationship between employee engagement and innovative work behavior across various levels of employees.

**H3a:** *There is a significant relationship between the dedication of faculty members and their innovative behaviour.*

#### *Vitality and Innovative Behaviour (H3b)*

Vitality in literature refers to the energy that is available to employees within an organization. The essential employees exhibit positive energy during their work. They experience a sense of mental and physical strength while working. The performance of these employees is frequently exceptional, while experiencing low levels of stress. Vitality is a significant factor influencing work engagement and is associated with employees' innovative work behaviour (Op den Kamp et al., 2020). Vitality in the workplace is recognized as a crucial factor for the efficient functioning of individuals. Organizations frequently seek various strategies to enhance productivity through vitality. Vitality is considered crucial for fostering innovative work behaviour in employees (Chong & Zainal, 2024). Feng et al. (2018) found that employee engagement is influenced by employee vitality.

**H3b:** *There is a significant relationship between the vitality of faculty members and their innovative behaviour.*

#### *Concentration and Innovative Behaviour (H3c)*

The concentration factor of work engagement indicates that employee concentration has a direct and significant impact on innovative work behaviour. Engaged and focused employees tend to be inventive, productive, responsible, and innovative. These employees are more inclined to provide additional services and fulfil responsibilities beyond their core duties. The level of employee engagement is significantly high. Employees who

demonstrate higher levels of loyalty, commitment, and innovation are more likely to exhibit these qualities in their job (Soetantyo & Ardiyanti, 2018).

Studies has indicated that concentration is a crucial factor in work engagement and has a significant impact on innovative work behaviour. Viitala et al. (2023) found that concentration has a significant impact on employees' work engagement and innovative behaviour. Concentration of employees enhances innovative work behaviour. Fostering a work environment that enhances concentration can drive innovation within private undergraduate schools.

**H3c:** *There is a significant relationship between the Concentration of faculty members and their innovative behaviour.*

#### *Mediating Role of Work Engagement (H4)*

Work engagement is crucial for shaping the culture of the organization and fostering innovative work behaviour among employees. The organization's culture fosters employee engagement, which in turn drives innovative work behaviour. A study also found that the organizational culture has a positive impact on employee engagement (Şengün & Tuğrul, 2023). While engaged employees demonstrate actions that enhance their innovative work behaviour (Sari et al., 2021).

The innovation behaviour of the employees is influenced by the consistency of the culture. Several studies have found a mediation relationship between work engagement and this path. The findings of Gu et al. (2014) indicate that a supportive organizational culture has a positive impact on the innovative behaviour of the workforce. However, work engagement serves as a connection between a consistent culture and innovative work behaviour. When an organization fosters a supportive culture, it positively impacts employee engagement, which in turn influences their behaviour.

Additionally, the employees who actively engage in organizational activities have a profound impact on fostering innovative work behavior (Yoerger et al., 2015). In addition, the employee's level of engagement is also influenced by the organization's mission. The findings of multiple studies indicate that employee engagement is influenced by a compelling and well-defined organizational mission, which in turn affects employees' innovative behaviour. Ultimately, the importance of employee engagement in mediating the relationship between cultural adaptability and employee innovative behaviour is evident (Siswanti et al., 2022). This study suggests that work engagement may play a role in connecting cultural dimensions and innovative work behaviour.

**H4:** *Work engagement plays a mediating role in the impact of organizational culture on innovative behaviour in private undergraduate schools.*

**H4a:** *Work engagement plays a mediating role in the impact of consistency on the innovative behaviour of faculty in private undergraduate schools.*

**H4b:** *Work engagement plays a mediating role in the impact of participation on the innovative behaviour of faculty in private undergraduate schools.*

**H4c:** *Work engagement plays a mediating role in the impact of mission on innovative behaviour of faculty in private undergraduate schools.*

**H4d:** *Work engagement plays a mediating role in the impact of adaptability on the innovative behaviour of faculty in private undergraduate schools.*

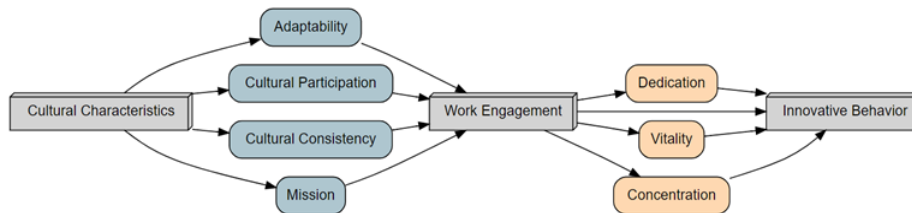

**Figure 1:** Theoretical Framework.

## Methodology

### *Research Design*

In this study, data is collected from the employees of private universities and colleges that offer undergraduate studies in this study. Considering the study's objectives, the current research is of a quantitative nature. In addition, the present study utilizes a cross-sectional research design. A questionnaire was created to gather data from the participants. In order to achieve this goal, a widely recognized and thorough scale was utilized. A model developed by Daniel Denison was utilized to measure innovation and organizational culture. This scale encompasses all four dimensions of corporate culture: mission, adaptability, consistency, and participation.

### *Population/Sample/Unit of Analysis and Data collection process*

The data for this study was gathered from employees working at private universities in China. The primary objective was to gather data from a wide range of individuals in order to make generalizations based on the findings. The questionnaire was distributed among 605 participants. A total of 556 valid responses were obtained for this study and were subsequently used for further analysis. The participants of the study were selected through a method called simple random sampling.

### *Analysis Scale*

#### *Measurement Scale for Cultural Characteristics*

The study utilized Denison's OCQ scale, which was adapted to collect data from the study participants. This scale was utilized for data collection of four dimensions: mission, adaptability, consistency, and participation.

#### *Measurement Scale of Work Engagement*

This study utilized the Utrecht Work Engagement Scale (UWES) to gather data on the work engagement of university employees.

#### *Measurement Scale for Innovative Behaviour*

In this study, the conceptualization of Amabile and George was adopted for the data collection of innovative behaviour.

Data Analysis Methods

The study employed various methods, such as descriptive statistics and correlational analysis, to analyze the data. The validity and reliability of the data were assessed using descriptive analysis tests. Correlation analysis was employed to investigate the relationship between the variables in the study.

Results

Correlation analysis and confirmatory factor analysis was used in the start of the result section. The CFA values of innovative work behaviour, work engagement and cultural dimension is acceptable as per the threshold level (CFI > 0.967, RMSEA < 0.053, GFI > 0.912, AGFI > 0.901). Likewise, significant positive correlation is witnessed among dimensions of the work engagement and innovative behaviour (p < 0.01). The dedication has more strong correlation with validity and focus.

Table 1

Confirmatory Factor Analysis (CFA) Results.

Construct	CMIN/DF	GFI	AGFI	CFI	RMSEA
Cultural Characteristics	1.341	0.912	0.901	0.967	0.053
Work Engagement	1.221	0.952	0.931	0.984	0.039
Innovative Behaviour	1.207	0.962	0.941	0.994	0.037

Table 1 shows the results of CFA showing good model fit of all three variables namely innovative work behaviour, work engagement and culture.

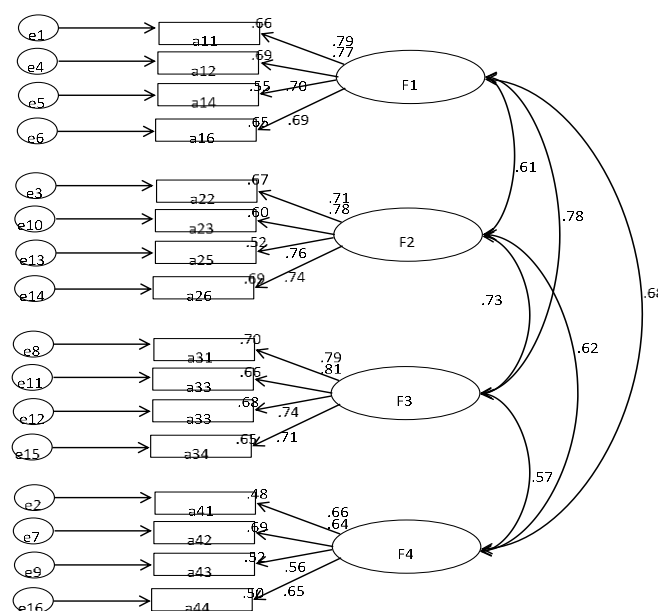

Figure 2: CFA Results.

The cultural characteristics have a CFI value of 0.967, indicating a high level of fit. The RMSEA value is 0.053, which is below the threshold of 0.08. Therefore, it is deemed acceptable. In addition, the GFI and AGFI values are 0.912 and 0.901, respectively. The value exceeds the threshold level of 0.90, indicating a satisfactory model fit. The CFIs for work engagement and innovative behaviour are 0.984 and 0.994, respectively. Furthermore, the RMSEA values are 0.039 and 0.037. Furthermore, the AGFI and GFI values exceed 0.90, indicating a high level of fit. The results of the CFA support the validity of the measurement model.

**Table 2**

*Correlation Between Various Dimensions of Work Engagement and Innovative Behavior of Faculty and Staff.*

variable	Correlation	focus	dedication	vitality	innovative behavior
focus	Pearson correlation	1	.394 **	.373 **	.447 **
	Significance (bilateral)		.000	.000	.000
dedication	Pearson correlation	.394 **	1	.638 **	.533 **
	Significance (bilateral)	.000		.000	.000
vitality	Pearson correlation	.373 **	.638 **	1	.528 **
	Significance (bilateral)	.000	.000		.000
innovative behavior	Pearson correlation	.447 **	.533 **	.528 **	1
	Significance (bilateral)	.000	.000	.000	

**Note a:** \*\*. Indicates significant correlation at the 0.01 level (two-sided)

The correlation matrix presented in the table above illustrates the connection between different dimensions of work engagement, specifically vitality, dedication, focus, and innovation work behaviour. Level of correlation is observed with  $P < 0.01$

- Focus shows a significant positive correlation with dedication ( $r = 0.394$ ), vitality ( $r = 0.373$ ), and innovative behaviour ( $r = 0.447$ ).
- Dedication exhibits a strong positive correlation with focus ( $r = 0.394$ ), vitality ( $r = 0.638$ ), and innovative behaviour ( $r = 0.533$ ).
- Vitality demonstrates a robust positive correlation with focus ( $r = 0.373$ ), dedication ( $r = 0.638$ ), and innovative behaviour ( $r = 0.528$ ).
- Innovative behaviour displays a strong positive correlation with focus ( $r = 0.447$ ), dedication ( $r = 0.533$ ), and vitality ( $r = 0.528$ ).

All these findings suggest innovative work behaviour among employees will be more in case of higher level of vitality, dedication and focus.

The analysis table explores the relationship between cultural traits, work engagement, and faculty innovative behaviour. It investigates how work engagement mediates this relationship through multiple steps.

In the initial phase of analysis, we begin by examining the connection between cultural factors such as adaptability, mission, participation, and consistency, and their positive correlation with innovative work behaviour. It is worth mentioning that participatory and

adaptability have been found to have a positive impact on innovative behaviour, as indicated by their positive  $\beta$  values. On the other hand, consistency has a negative impact, as suggested by its negative  $\beta$  value.

**Table 3**

*Verification Analysis Table of The Mediating Role of Work Engagement Between Cultural Traits and Faculty Innovative Behavior.*

step	Explanatory variables	Explained variable	$\beta$ value	overall model	Establishment conditions
one	consistency	Faculty and Staff innovative behaviour	-0.020**	14.887	Significantly
	participatory mission		0.154**		Significantly
	Adaptability		0.042**		Significantly
two	consistency	Work engagement	0.070**	11.822	Significantly
	participatory mission		0.081		Not significant
	Adaptability		0.058		Not significant
three	vitality	Faculty and Staff innovative behaviour	0.262**	15.816	Significantly
	dedication		0.138**		Significantly
	focus		0.053**		Significantly
Four	consistency	Faculty and Staff innovative behaviour	0.072**	20.494	Significantly
	participatory mission		0.101**		Significantly
	Adaptability		-0.137		Not significant
	Work engagement		0.578**		Significantly
			0.075		Not significant
			0.101		Not significant
			0.683**		Significantly

**Note a:** \*\*. Indicates significant correlation at the 0.01 level (two-sided)

At the second stage, the impact of adaptability and mission with culture is found significant. The third step introduces vitality, dedication, and focus as explanatory variables for faculty innovative behaviour. All three variables demonstrate significant correlations, indicating their positive impact on innovative behaviour.

Finally, In the fourth step, when work engagement is reintroduced as the explained variable, there are significant correlations between participatory cultural traits, work engagement itself, and faculty innovative behaviour. It appears that the presence of participatory cultural traits has a direct impact on innovative behaviour and also indirectly influences it by fostering work engagement.

In this analysis, the focus is on the complex connection between cultural traits, work engagement, and faculty innovative behaviour. It is found that some traits have a direct impact, while others influence through work engagement.

The analysis of the hypotheses regarding the impact of private undergraduate schools on faculty and staff innovative behaviour, as well as work engagement, uncovers a number of noteworthy findings. Firstly, it is important to note that Hypothesis H1 has been firmly established. The results have shown a positive correlation between cultural characteristics and innovative behaviour, providing strong support for the hypothesis. This highlights the significant impact that private undergraduate schools can have on fostering innovative behaviour.

**Table 4**

*Hypothetical conclusion.*

Hypothesis	Hypothetical Items	Prove the Result
H1	The culture of private undergraduate universities significantly correlates with the innovative behaviour of its employees.	Established
H1a	The cultural adaptability characteristics of private undergraduate schools have a significant impact on the innovative behaviour of faculty.	Established
H1b	The cultural participation characteristics of private undergraduate schools have a significant impact on the innovative behaviour of faculty.	Established
H1c	The cultural consistency characteristics of private undergraduate schools have a significant impact on the innovative behaviour of faculty.	Established
H1d	The cultural mission characteristics of private undergraduate schools have a significant impact on the innovative behaviour of faculty.	Established
H2	There is a significant correlation between the cultural characteristics of private undergraduate universities and the work engagement of faculty.	Partially Established
H2a	The cultural participation characteristics of private undergraduate school culture have a significant impact on work engagement.	Invalid
H2b	The cultural adaptive characteristics of private undergraduate school culture have a significant impact on work engagement.	Invalid
H2c	The cultural consistency characteristics of private undergraduate school culture have a significant impact on work engagement.	Established
H2d	The cultural mission characteristics of private undergraduate school culture have a significant impact on work engagement.	Established
H3	There is a significant relationship between faculty work engagement and their innovative behaviour.	Established
H3a	There is a significant relationship between the dedication of faculty members and their innovative behaviour.	Established
H3b	There is a significant relationship between the vitality of faculty members and their innovative behaviour.	Established
H3c	There is a significant relationship between the Concentration of faculty members and their innovative behaviour.	Established
H4	Work engagement plays a mediating role between the impact of cultural characteristics of private undergraduate schools on faculty innovative behaviour.	Partially Established
H4a	There is a significant relationship between the Concentration of faculty members and their innovative behaviour.	Established
H4b	Work engagement plays a mediating role in the impact of participation on the innovative behaviour of faculty in private undergraduate schools.	Invalid
H4c	Work engagement plays a mediating role in the impact of mission on innovative behaviour of faculty in private undergraduate schools.	Established
H4d	Work engagement plays a mediating role in the impact of adaptability on the innovative behaviour of faculty in private undergraduate schools.	Established

In addition, the hypotheses H1a, HB, H1c, and H1d, which examine various cultural aspects like adaptability, participation, consistency, and mission, all provide evidence of a positive impact on innovative behaviour. This strengthens the connection between organizational culture and faculty innovation.

However, the analysis also uncovers certain subtleties. The study has found evidence supporting hypotheses H2, H2c, and H2d, which highlight the positive influence of private undergraduate schools on work engagement. These findings suggest a significant link between organizational culture and employee engagement.

On the other hand, Hypotheses H2a and H2b, which focus on the influence of cultural characteristics on work engagement, have been found to be invalid. This indicates the necessity for additional research or improvement in our understanding of this relationship.

In the future, it is evident that the positive impact of work engagement on faculty and staff innovative behavior is emphasized. This confirms the significance of employee dedication, vitality, and concentration in promoting innovation within private undergraduate schools. Regarding the mediation results, it is worth noting that all mediating results, except for H4b, have shown significant findings.

## Discussion

This study seeks to examine the impact of cultural factors on employee engagement and innovative work behaviour. Work engagement was also examined as a mediating factor in the provided framework. The data was gathered from the employees of private universities and colleges in China. The collected data was analysed using CFA and a correlation matrix table. The study's findings provide strong empirical support for the proposed framework.

The results of the study shows that culture and its factors namely mission, participation, and adaptability have significant effect on employee innovative work behaviour. These results are in line with the findings of [Siswanto \(2023\)](#) of the past studies who revealed same findings in their study. The employee who is participating in the organizational activities is more likely to innovative in his or her behaviour. Such person understands all of the organizational processes. In this scenario, the employee is open to taking risks, provided that the culture supports it. Therefore, the organization's mission takes on great significance, as it must foster innovation and flexibility. The role of leadership is crucial in fostering a culture that encourages innovative behaviour among employees in educational institutes. The respondents of the study believe that educational institutions should prioritize the development of strategies that foster an innovative culture.

The results of this study indicate that employee work engagement has a significant impact on innovative work behaviour. Employees who are actively involved in the organisation are more likely to exhibit innovative work behaviour. These findings can be attributed to a variety of factors. Firstly, individuals who are committed to their work are willing to go above and beyond to achieve the goals of the organisation. This individual is highly dedicated to achieving their goals and objectives, both personally and within the organisation. The individual's level of dedication and determination towards their objectives is commendable. They are highly motivated and driven to accomplish assigned tasks. Thus, the results of this study indicate that when university employees are more engaged, it positively impacts their level of innovative work behaviour. In a previous study, [Siswanti et al. \(2022\)](#) also discovered similar results.

The study's findings further confirmed the positive impact of organisational culture on employee work engagement. Put simply, the organization's ability to adapt and its mission play a crucial role in shaping employee work engagement. An individual who is supported by the organisation to go above and beyond in order to achieve the organization's goals is seen as displaying loyalty towards the organisation. This employee demonstrates a strong dedication to achieving the goals and objectives of the organisation. The findings of the study indicate that colleges and universities should prioritise their mission and cultivate a culture that is adaptable in order to foster employee engagement. The [Şengün et al. \(2023\)](#) also found similar results in their study.

## Conclusion

In this section, we will synthesise the results of the study. The study's findings highlight the significant impact of cultural factors on employee engagement and innovative work behaviour. In addition, the level of employee engagement in educational institutions is closely linked to their ability to exhibit innovative work behaviour. To obtain these results, the present study collected data from employees of Chinese universities. The collected data was analysed using correlation analysis and CFA techniques.

The study findings indicate that the cultural characteristics of employees at educational institutes have a significant impact on their innovative work behaviour. When it comes to innovative work behaviour, mission, participation, and adaptability of the culture play a crucial role. These findings underscore the significance of a culture that is adaptable and encouraging. The study's findings highlight the significant impact of work engagement on employee innovative work behaviour. The research demonstrates the significance of work engagement in fostering innovation among university employees. The dimensions of focus, dedication, and vitality are crucial for fostering innovative work behaviour. The employee, who is committed and driven towards the goals of the organisation, will undoubtedly foster a culture of innovation among the employees.

In addition, the study's findings provide some support for the idea that culture can have a significant impact on employee work engagement. The culture of the organisation should be flexible and in line with the mission to benefit the employees. Statistical support is found for the mediating role of work engagement in the present study.

### **Limitations, Theoretical and Practical Contributions**

There are a few limitations in the current research, despite efforts to address all aspects. This study utilised a cross-sectional research design due to time constraints. Furthermore, future research can employ a longitudinal research design to gather more comprehensive data. This study adopts a quantitative approach. Future researchers may consider utilising a mixed research method to analyse and evaluate the study's findings from both qualitative and quantitative perspectives. However, this study gathered data from educational institutions in China, while future research has the potential to collect data from educational institutions in any other country.

This research has significant contributions in both practical and theoretical aspects. This study significantly contributes to the existing body of knowledge by examining the direct and indirect effects of cultural dimensions on innovative work behaviour, thereby expanding our understanding in this area. This study contributes to the existing body of knowledge by investigating the role of work engagement, including its dimensions, in mediating the relationship between cultural factors and innovative work behaviours. The findings of the study greatly contribute to the existing understanding of innovation and organisational behaviour. This study contributes to the existing body of literature in management studies by exploring the intricate connection between cultural factors, innovative behaviour, and work engagement.

Regarding the practical implications of the studies, educational institute management can utilise these findings to enhance their cultural factors. They have the opportunity to enhance the mission statement of their organisation. In addition, the organisation can prioritise employee participation in various activities to enhance engagement and promote positive work behaviour. Furthermore, the study's findings highlight the significance of work engagement within educational institutions. By incorporating various cultural factors, the long-term productivity and performance of employees can be enhanced.

### **References**

- Afrifa Jr, S., Fianko, S. K., Amoah, N., & Dzogbewu, T. C. (2022). The Effect of Organizational Culture on Employee Work Engagement in a Higher Education

- Institution. *Organizational Cultures: An International Journal*, 22(2), 1-89. <https://doi.org/10.18848/2327-8013/CGP/v22i02/89-104>
- Alateeg, S., & Alhammadi, A. (2024). The Impact of Organizational Culture on Organizational Innovation with mediation role of Strategic Leadership in Saudi Arabia. *Journal of Statistics Applications & Probability*, 13(2), 843-858. <https://doi.org/10.18576/jsap/130220>
- Alredaisy, S. M. A. H. (2023). The influence of participation in decision making on teaching staff's performance in the Faculty of Education, University of Khartoum, Sudan. *Al-Qazm Journal of Economic and Social Studies*, 83-100. <https://search.mandumah.com/Record/1407471>
- Badawi, H. T., & Susilo, P. (2019). Organizational Culture Adaptability and SMEs Business Performance through Business Innovation. *ICEMAB 2018: Proceedings of the 1st International Conference on Economics, Management, Accounting and Business, ICEMAB 2018, 8-9 October 2018, Medan, North Sumatra, Indonesia* (pp. 287). European Alliance for Innovation. <https://doi.org/10.4108/eai.8-10-2018.2288717>
- Beidokhti, A. A., Fathi, K., & Moradi, S. (2016). The structural relations of parameters of school-based management based on decentralization, responsibility, participation, organizational culture, and organizational commitment. *Review of European Studies*, 8(2), 159-170. <https://doi.org/10.5539/res.v8n2p159>
- Chatman, J. A., & O'Reilly, C. A. (2016). Paradigm lost: Reinvigorating the study of organizational culture. *Research in organizational behavior*, 36, 199-224. <https://doi.org/10.1016/j.riob.2016.11.004>
- Chong, Y. K., & Zainal, S. R. M. (2024). Employee agility's moderating role on the link between employee vitality, digital literacy and transformational leadership with job performance: an empirical study. *Cogent Business & Management*, 11(1), 2337447. <https://doi.org/10.1080/23311975.2024.2337447>
- Feng, J., Zhang, Y., Liu, X., Zhang, L., & Han, X. (2018). Just the right amount of ethics inspires creativity: A cross-level investigation of ethical leadership, intrinsic motivation, and employee creativity. *Journal of Business Ethics*, 153(3), 645-658. <https://doi.org/10.1007/s10551-016-3297-1>
- Fitriana, A., & Satrya, A. (2022). Employee Service Innovative Behavior in the Public Sector: The Role of Proactive Personality and Work Engagement. *19th International Symposium on Management (INSYMA 2022)* (pp. 423-432). Atlantis Press. [https://doi.org/10.2991/978-94-6463-008-4\\_53](https://doi.org/10.2991/978-94-6463-008-4_53)
- Fuad, D. R. S. M., Musa, K., & Hashim, Z. (2022). Innovation culture in education: A systematic review of the literature. *Management in Education*, 36(3), 135-149. <https://doi.org/10.1177/0892020620959760>
- Gabel-Shemueli, R., Westman, M., Chen, S., & Bahamonde, D. (2019). Does cultural intelligence increase work engagement? The role of idiocentrism-allocentrism and organizational culture in MNCs. *Cross Cultural & Strategic Management*, 26(1), 46-66. <https://doi.org/10.1108/CCSM-10-2017-0126>
- Gorton, G. B., & Zentefis, A. K. (2020). *Corporate culture as a theory of the firm*. National Bureau of Economic Research.
- Gu, Y., Zhou, W., & Peng, J. (2014). Research on the impact mechanism of organizational support on R&D personnel's innovative behavior. *Management Science*, 27(1), 109-119. <http://www.cqvip.com/qk/96668a/201401/48585559.html>
- Hansen, J. A. J., & Pihl-Thingvad, S. (2017). *Leadership styles and innovative Work behavior*. Paper presented at the Paper presented at 21st International Research Society on

- Public Management Conference, Budapest, Hungary. rom URL
- Hock-Doeppen, M., Montasser, J. S., Klein, S., Clauss, T., & Maalaoui, A. (2024). The role of innovative work behavior and organizational support for business model innovation. *R&D Management*, 1-20. <https://doi.org/10.1111/radm.12671>
- Husin, N. H., Mansor, N. N. A., Kelana, B. W. Y., & Sondoh Jr, S. L. (2021). Employee participation and innovative work behaviour: The mediation effect of work engagement. *International Journal of Academic Research in Business and Social Sciences*, 11(7), 1043-1055. <https://doi.org/10.6007/IJARBS/v11-i7/10571>
- Kananu, K. M., Ambrose, K., & Joel, T. (2020). The effect of employee engagement on the relationship between leader-member exchange and innovative work behaviour in Kenya. *Journal of Business and Economic Development*, 5(3), 113. <https://doi.org/10.11648/JJBED.20200503.11>
- Khairi, H. (2022). A Model for Simplifying the Organizational Structure of the Bureaucracy in Indonesia. *Transformation: Journal of Government Management*, 14(1), 12-31. <https://doi.org/10.33701/jtp.v14i1.2349>
- Khalid, B., Butt, F. S., Ali, M. I., Yasmin, R., & Satti, M. Q. (2021). The Conditional Indirect Effect Model of Employees' Innovative Work Behavior. *IBT Journal of Business Studies*, 17(2), 116-133. <https://www.ibtjbs.ilmauniversity.edu.pk/arc/Vol17/i2p2>
- Khusanova, R., Kang, S.-W., & Choi, S. B. (2021). Work engagement among public employees: Antecedents and consequences. *Frontiers in psychology*, 12, 684495. <https://doi.org/10.3389/fpsyg.2021.684495>
- Liu, F., Chow, I. H.-S., Zhang, J.-C., & Huang, M. (2019). Organizational innovation climate and individual innovative behavior: exploring the moderating effects of psychological ownership and psychological empowerment. *Review of Managerial Science*, 13, 771-789. <https://doi.org/10.1007/s11846-017-0263-y>
- Op den Kamp, E. M., Bakker, A. B., Tims, M., & Demerouti, E. (2020). Proactive vitality management and creative work performance: The role of self-insight and social support. *The Journal of Creative Behavior*, 54(2), 323-336. <https://doi.org/10.1002/jocb.368>
- Pradhan, S., & Jena, L. K. (2019). Does meaningful work explains the relationship between transformational leadership and innovative work behaviour? *Vikalpa*, 44(1), 30-40. <https://doi.org/10.1177/0256090919832434>
- Purc, E., & Laguna, M. (2019). Personal values and innovative behavior of employees. *Frontiers in psychology*, 10, 439048. <https://doi.org/10.3389/fpsyg.2019.00865>
- Radu, C. (2023). *Fostering a positive workplace culture: Impacts on performance and agility*. Human Resource Management - An Update. <https://doi.org/10.5772/intechopen.1003259>
- Ramadhani, H., Musnadi, S., & Kesuma, T. M. (2022). The Role of Work Engagement and Innovative Behavior in Mediating the Effect of Happiness at Work on Employee Performance with Service Climate as a Moderation on Employees of Bank Syariah Indonesia. *International Journal of Scientific and Management Research*, 5(10), 74-84. <https://doi.org/10.37502/IJSMR.2022.51006>
- Sadegh Sharifirad, M., & Ataei, V. (2012). Organizational culture and innovation culture: exploring the relationships between constructs. *Leadership & Organization Development Journal*, 33(5), 494-517. <https://doi.org/10.1108/01437731211241274>
- Sari, D. K., Christian, F., & Yudianto, A. (2021). Work engagement and innovative work behavior: Meta-analysis study. *Proceedings of the International Conference on Psychological Studies (ICPSYCHE 2020)*. 530(53) (pp. 359-366). Atlantis Press. <https://doi.org/10.2991/assehr.k.210423.053>

- Şengün, D. U., & Tuğrul, T. (2023). Exploring the Relationship between Organizational Cultures, Openness to Experience and Work Engagement. *Proceedings of the International Conference on Business Excellence*, 17(1) (pp. 2108-2118). <https://doi.org/10.2478/picbe-2023-0184>
- Singh, Y. (2019). Employee engagement as a contemporary issue in HRM. In *Management Techniques for Employee Engagement in Contemporary Organizations* (pp. 20-45). IGI Global. <https://doi.org/10.4018/978-1-5225-7799-7.ch002>
- Siswanti, Y., & Nurhariati, E. (2022). The influence of organizational culture to innovation behavior: a hierarchical linear modelling approach. *Journal of International Conference Proceedings*, 5(5) (pp. 267-284). <https://doi.org/10.32535/jicp.v5i5.2087>
- Siswanto, A. (2023). The Influence of Organizational Culture on Employee Engagement: The Role of Organizational Commitment As An Intervening Variable. *Greenation International Journal of Tourism and Management*, 1(2), 171-183. <https://doi.org/10.38035/gijtm.v1i2.46>
- Soetantyo, T., & Ardiyanti, N. (2018). Innovative behavior, learning organization, and the mediating role of work engagement in it sector. *Asia Pacific Institute of Advanced Research (APIAR)*, 1-12. <https://apiar.org.au/wp-content/uploads/2018/10/2-APCCR-Aug18-BRR754-Bus-1-12.pdf>
- Srirahayu, D. P., Ekowati, D., & Sridadi, A. R. (2023). Innovative work behavior in public organizations: A systematic literature review. *Heliyon*, 9(2), e13557. <https://doi.org/10.1016/j.heliyon.2023.e13557>
- Viitala, R., Laiho, M., Pajuoja, M., & Henttonen, K. (2023). Managerial coaching and employees' innovative work behavior: The mediating effect of work engagement. *The International Journal of Entrepreneurship and Innovation*, 14657503231221693. <https://doi.org/10.1177/14657503231221693>
- Villarroya, A. A. (2017). The cultural mission of universities. *Debats. Revista de cultura, poder i societat*, 2(2), 175-194. <https://doi.org/10.28939/iam.debats-en.2017-14>
- Vithayaporn, S., & Ashton, A. S. (2019). Employee engagement and innovative work behavior: A case study of Thai Airways International. *ABAC ODI Journal Vision. Action. Outcome*, 6(2), 45-62. <http://www.assumptionjournal.au.edu/index.php/odijournal/article/view/3881>
- Warrick, D. D. (2017). What leaders need to know about organizational culture. *Business Horizons*, 60(3), 395-404. <https://doi.org/10.1016/j.bushor.2017.01.011>
- Yamak, O. U., & Eyupoglu, S. Z. (2021). Authentic leadership and service innovative behavior: mediating role of proactive personality. *Sage Open*, 11(1), 2158244021989629. <https://doi.org/10.1177/2158244021989629>
- Yan-mei, Z., & Zheng-tang, Z. (2020). Moderating Effect of Servant Leadership on the Motivation Mechanism of Organizational Innovation Climate Affecting Employees' Innovation Behavior. *Journal of South China normal University (Social Science Edition)*, 2020(6), 127-141. <https://journal-s.scnu.edu.cn/en/article/id/ffbde088-f33c-4d58-bd07-80805aeaf9b0>
- Yang, X., Feng, Y., Meng, Y., & Qiu, Y. (2019). Career adaptability, work engagement, and employee well-being among Chinese employees: The role of guanxi. *Frontiers in psychology*, 10, 441081. <https://doi.org/10.3389/fpsyg.2019.01029>
- Yoerger, M., Crowe, J., & Allen, J. A. (2015). Participate or else!: The effect of participation in decision-making in meetings on employee engagement. *Consulting Psychology Journal: Practice and Research*, 67(1), 65. <https://doi.org/10.1037/cpb0000029>
- Yu, T., Zhao, Y., & Zhang, Z. (2023). The direction of work flow matters: influence

- mechanism of task interdependence on employee proactive work behavior. *Frontiers in psychology*, 14, 1176862. <https://doi.org/10.3389/fpsyg.2023.1176862>
- Zhang, G., & Wang, Y. (2022). Organizational identification and employees' innovative behavior: the mediating role of work engagement and the moderating role of creative self-efficacy. *Chinese Management Studies*, 16(5), 1108-1123. <https://doi.org/10.1108/CMS-07-2021-0294>
- Zhu, C., & Zhang, F. (2020). How does servant leadership fuel employee innovative behavior? A moderated mediation framework. *Asia Pacific Journal of Human Resources*, 58(3), 356-377. <https://doi.org/10.1111/1744-7941.12227>