



Leadership Styles and School Performance: A Study Examining Factors Contributing to Education Success in Medan, Indonesia *

Syawal GULTOM ^{*11}, Baharuddin²², Hesti FIBRIASARI ³³

ARTICLE INFO

ABSTRACT

Article History:

Received: 10 Dec.2020

Received in revised form: 17 Mar. 2021

Accepted: 10 May 2021

DOI: 10.14689/ejer.2021.93.17

Keywords

school performance, leadership styles, education leadership, education system

Purpose: Leadership styles and school performance in educational sector are correlated in the sense that to improve the quality of education, there is a great need to develop the professional capabilities of school leaders-- the headmaster, head teachers and department heads, who are responsible for managing school resources effectively and efficiently. In Indonesia particularly, educational management through good leadership is one of the most required

aspects to develop. **Research Methodology:** The study examines leadership styles of school heads from sample schools around Medan city in the Province of North Sumatra, Indonesia and critically analyze their performance styles in running schools. A correlational survey design was employed, which helped establish the relationship between leadership styles and management performance in schools. The study involved examining documentation, visiting schools, and holding discussions with various head teachers and department heads purposively to evaluate the current status of educational management in Indonesia.

Findings: The findings revealed that good performance of a school depends on good governance and better leadership style of the school head, established as performance characteristics that every school leadership must possess. **Implications:** The present study will be a useful contribution to understand the leadership styles and school performance in the Indonesian education sector. It will provide useful insights of leadership styles as a crucial element in growth and development of the Indonesian education sector.

© 2021 Ani Publishing Ltd. All rights reserved.

* Corresponding Author, Universitas Negeri Medan, INDONESIA, e-mail: syawalgultom@unimed.ac.id, ORCID: 0000-0001-0000-0001-9766-2438

²Universitas Negeri Medan, INDONESIA, ORCID: 0000-0002-5109-8090

³Universitas Negeri Medan, INDONESIA, ORCID: 0000-0002-8009-4603

Introduction

In the Indonesian context, it is generally believed that their education system suffered with low quality of human resources and falling school performance due to the lack of strong educational leadership and poor leadership styles (Aldhaheeri, 2017). In such a situation, any new demands and efforts for improvement are not only focused on improving the quality of education of teaching and learning but more fundamentally on the quality of the processes driven by the power of educational leadership and performance (Al-Sada, Al-Esmael, & Faisal, 2017). According to Torlak and Kuzey (2019), leadership is fundamental to school improvement and transformation. However, the most respected form of school leadership is that which is effective when it is reflected in good performance on duty. Headmasters have an important role in achieving quality education and achieving the expected performance levels.

The fact that education is becoming complex, quality leadership is being recognized as a key to a school's success (Elrehail, Emeagwali, Alsaad, & Alzghoul, 2018). Effective school leadership can control, support, maintain, and continue to encourage the growth of the commitment of all school personnel, and always offer quality education services consciously and with dignity. S. Jones and Harvey (2017) assert that transformational leadership leads to higher collective efficacy, greater teacher commitment to school mission, school community, and school-community partnerships, hence higher student achievement (Csachova, 2020; Dollete, 2020; Aksoy-Pekacar et al., 2020).

Owing to growing complexity of issues in the education sector and growing expectations from school headmasters and school leadership, there is a need of strong leadership and professional school head teachers who can perform and deliver good. Yaseen, Ali, and Asrar-ul-Haq (2018) argue that a good leadership style facilitates the instilling of values among students. Saleem, Batool, and Khattak (2017) believe that professional leadership increases the chance of better performance and attaining a quality educational system. Their study reports that leadership influenced teacher creativity by 46.7%, while the principal's performance represented through good management influenced quality education by 58.9%, with an overall influence of 59% on school performance if all factors are taken in consideration (Palupi & Kantun, 2019). The distribution of all higher education institutions in Indonesia has been provided in Figure 1 given below:

Number of Indonesian Higher Education Institutions by Type

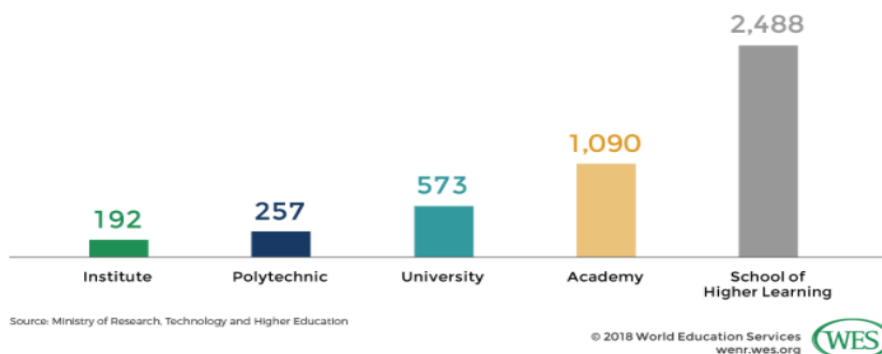

Figure 1: Higher education institutions in Indonesia

Unfortunately, in the Indonesian context, professional development of school headmasters is still of poor quality and less capable to meet the demands of the current global development of leadership styles and performance in schools (Anderson, 2017). Despite knowing that leadership is an important element in any school’s performance, Indonesia’s recruitment processes and awarding leadership roles in schools have led to a low level of school performance across the archipelago. The government is committed to providing inclusive, high quality and affordable education to all its nationals. Studies have revealed that in order to a strong education system in Indonesia, there is a need to hire competent head teachers, who should be identified through an improved recruitment system (Dopson et al., 2019).

Literature Review

Many studies have revealed that successful school leadership plays a key role in the learning process, including the school leadership style and school performance. This means that with a good management structure, heads of schools can positively influence teacher performance, hence influencing student’s achievement on academics. In a presentation on the landscape of leadership development in China, Kiran and IkramKayani (2020) established that leadership is fundamental to school improvement and achievement. Elbaz and Haddoud (2017) found that transformational leadership has higher collective efficacy, greater teacher commitment to school mission, school community, and school-community partnerships, hence higher student achievement. In support of this view, Dartey-Baah and Mekpor (2017) are of a similar view where they established in their study that leadership influenced teacher creativity by 46.7%, while the principal’s performance represented through good management influenced quality education by 58.9%, with an overall influence of 59%.

Teachers are always performing an instructional leadership duty where they are in direct contact with students. This implies that instructional leadership greatly influences student achievement whether directly or indirectly. This is always in close relationship with the school leadership's behaviour which directly affects teachers and influences the school culture, hence indirectly affecting student achievement. Research has revealed that effective leaders contribute to the development a good performance working culture in schools, by taking in consideration: the social expectations, engaging all stakeholders, including the students, parents and the public, delegating leadership and evaluating the performance of the school system (Eliyana & Ma'arif, 2019).

Leadership styles and school performance encourage close communication and cooperation among two or more people (or in students) appropriately and efficiently of delivering and receiving education, with the essence of ensuring that the intended message is understood by the students. In portfolio records, it can be easily documented, but in the ideal situation, a head teacher must only focus on administrative duties. Making leadership as an additional task encourages heads of schools to become liars because, in the end, they are forced to make periodic assessments which are full of lies, leading to poor management, which is harmful to a school's operation. In other words, recruiting school head teachers as a reward is very wrong more so when the position of headship is given to a person as a favor. This hinders the improvement of the quality of education something highly expected by the parents and the public in general (Dalati, Raudeliūnienė, & Davidavičienė, 2017).

Education leadership is one of the foundations of national growth because a good education system will not harbor corruption which is the mother of a country's destruction, since it leads to mistrust, and hinders the development of a nation (Veliu, Manxhari, Demiri, & Jahaj, 2017). Good leadership plays a role in improving the quality of education. Studies continue to reveal that leadership is close to the quality of something taken care of, for instance, leadership style affects school operations either positively or negatively, including influencing the school discipline, learning culture and student's behavior. School leadership is faced with the challenge of implementing a focused educational development, planning, and sustainable quality improvement education program (Kairys, 2018).

Within this framework, the perceived need for improved management of a head teacher professionally depends on the successful implementation of government programs. Elrehail (2018) points out that a good head teacher should know that is responsible for the educational achievements made in a school. The responsibilities of a good head teacher, include intellectual development of the learners, moral shaping of the students, emotional nurturing of the students and physical health development of the learners. Good school leadership is also built based on honesty or trust, self-control and confidence, ability and responsibility, readiness to take risks and making decisions, being emotionally stable and socially intelligent. School leadership professionalism and ability are reflected in the head teacher's ability to understand every situation in school, the capacity to understand students learning needs and able to address them appropriately and of course has the ability and capacity to facilitate the development of the staff members found in the school (Arar & Nasra, 2019).

Schools require to implement government-designed programs; hence the leadership aspect should be dynamic both in idea and practice, with leaders demonstrating active participation and professionalism in performance. However, in the new leadership paradigm shift, Courtney (2018) observes that performance is influenced by five phases which comprise of building trust, engaging fully in one's culture, being determined to face social dominance and social justice, improving instructional practices and engaging all community stakeholders. Schools which operate under such a new paradigm shift, make greater signs of progress because there is continuous improvement in the system. This also indicates that leaders are able to provide guidance and are willing to build a formidable team at work through open two-way communication, and tasks delegation structure.

From the above, it can be argued that school leaders must be of good character: one who should have basic skills of leadership; should be experienced and professional at work; should exhibit a good knowledge and understanding of administration and supervision (Al-Husseini, El Beltagi, & Moizer, 2019). This study aimed to examine the school leadership and to understand what aspects could lead to a good school performance in the context of Indonesian education sector. This study reiterates the premise that, with the rapid change in the world over, school leadership is required to act professionally following the new management paradigms.

Problem Statement

Education leadership for Indonesia is a necessity if the country is to consolidate its position as a rapidly growing economy. Education leadership of good quality plays the role of enhancing a country's growth and development. However, there are reports which also mention that the level of competence and professionalism of head teachers, particularly for Secondary Schools across the archipelago, is still low in quality (Lukiyanto, 2018). This shows that the head teachers in Indonesia do not have the competences needed to run an efficient school management system. To overcome the challenges of development, there is a need to build a competent and professional leadership culture for schools in Indonesia, especially for Medan and the other surrounding regions. In Medan though the local education leadership tried to improve its education services, by encouraging good school governance (Udin, Handayani, Yuniawan, & Rahardja, 2019), but challenges of education leadership still loom over the local secondary schools.

Holbert, Madhakomala, Saparuddin, and Timotius (2021) admitted that as one of the local leaders he has never seen any significant improvement in the education system. He emphasized on the need to have multiple systems including the leadership for advancing education, education zoning system and providing incentives to teachers in the form of increased salaries (Guterresa, Armanu, & Rofiaty, 2020). The deteriorating condition of school head teacher's competencies is further exacerbated by ineffective recruitment system which is not based on merit. When a poorly managed education system is built upon incompetent and corrupt activities, it erodes public trust, impedes equality, and hinders development (Firdausy, 2019).

There are several trouble spots which must be removed specifically to stop the ambiguity and inadequacy in the recruitment process. There is also the need to reevaluate policy regarding school leadership. For instance, considering leadership in

the form of headmaster in school as just a mere additional task makes most heads reluctant and non-performing individuals. They consider that to be a school head teacher and to carry out the school leadership duties does not require professional leadership capabilities. According to them, leadership is following all duties outlined by administrative bureaucrats from the top, i.e., from the district administration to municipal governance, from provincial education department to the central government education ministry (Notanubun, 2020). Secondly, in most cases, head teachers work also as classroom teachers, who have the obligation of dividing time between leadership and their primary school duties of teaching. This also leads to inefficiency in their administration. Headship therefore should be considered as an essential task where heads of schools should be appointed specifically only for this purpose, and not to be assigned any other task such as teaching (Triraharjo, Aima, & Sutawijaya, 2019). Hence, there is a need to inculcate professionalism in order to improve and streamline current education system.

The above problems form the basis of analysis for this study to investigate the characteristics and performance of headmaster's leadership in Indonesia. The results of this study would illustrate how the position of the headmaster can be consolidated, and how a paradigm shift can be brought by reexamining the leadership styles and school performance in the Indonesian context. It would also help to formulate effective strategies and guidelines to establish the position of the headmaster in a professional role.

Methodology

This study was conducted in Medan city in the Province of North Sumatra, Indonesia. This study examined leadership styles of school heads and critically analyzed their performance in running schools in the region of Medan city in Indonesia. A correlational survey research design was employed, which helped establish the relationship between leadership styles and management performance of head teachers in the context of a school. Data was collected through documentation study, school visits, group discussions with head teachers and department heads, with the view to understand the exact situation of educational management in Indonesia. The data collection techniques included observations and guided questionnaires administered on school heads and heads of the selected departments. The level of quality of headmasters and teachers studied were those certified because it was believed that they had passed the basic requirement before qualifying for certification by the Indonesian government.

This study has executed the smart-PLS to examine the nexus among variables because the large sample size has been used and hypotheses testing is the purpose of the study (Hair Jr, Babin, & Krey, 2017). This study has taken four predictors such as communication style of education leadership (CSEL) with six items, communication style of school leadership (CSSL) with four items, school leadership (SL) with five items and school management system (SMS) also with five items. This research also used the school performance (SP) as the dependent variable with four items. These constructs are shown in Figure 2.

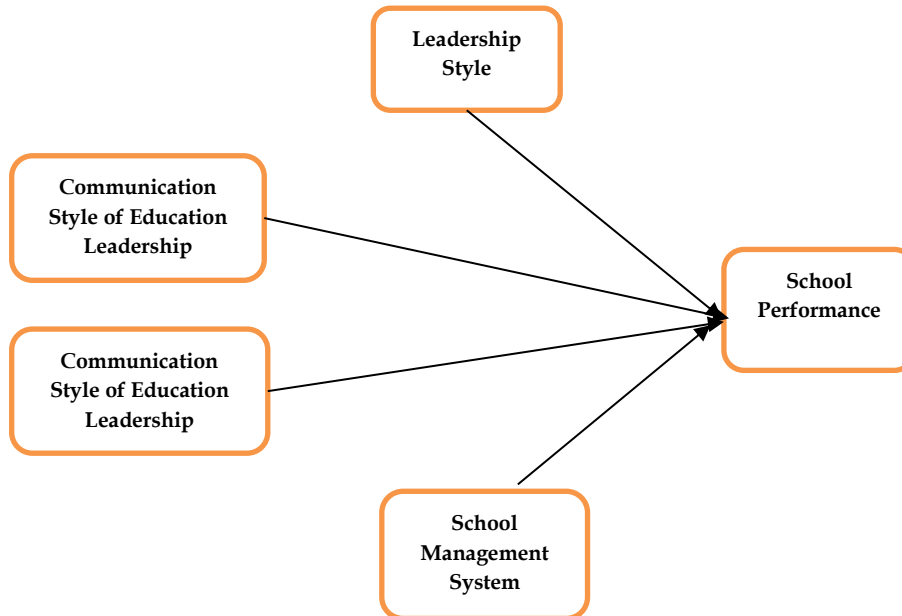

Figure 2: Theoretical model

Sampling and Population

Medan is the capital city of North Sumatra Province and with a total number of 337 middle high schools and 288 high schools, comprising of government-owned, private, religious and international schools. The target population of this study comprised both high school and junior high school teachers and heads of schools within Medan city. The population identified for this study comprised 1220 respondents chosen by using a simple size software calculator. Out of these 1220 respondents, the purposeful and random sampling method was used to select 990 of respondents comprising of head teachers, teachers and students, who belonged to 40 schools from within Medan city. The purposeful and random sampling were easiest sampling methods for choosing appropriate respondents from a target population. A total of 990 survey questionnaires were sent but received only 760 surveys that represents approximately 76.77 percent response rate. The sample of the study was large enough to generalize and encourage implementation of the findings in the entire education system of North Sumatra Province as well as of Indonesia as a country.

Findings

This research has examined the correlation among items that is known as convergent validity. The statistics show that the Alpha and CR values cross the standard of 0.70 and AVE and loading values are also not less than 0.50. These values show a high correlation among items. These values are highlighted in Table 1.

Table 1

Convergent validity

Constructs	Items	Loadings	Alpha	CR	AVE
Communication Style of Education Leadership	CSEL1	0.856	0.832	0.880	0.594
	CSEL2	0.765			
	CSEL3	0.762			
	CSEL5	0.750			
	CSEL6	0.715			
	Communication Style of School Leadership	CSSL2			
School Leadership	CSSL3	0.906	0.802	0.865	0.565
	CSSL4	0.746			
	SL1	0.782			
School Management System	SL2	0.837	0.773	0.803	0.511
	SL3	0.826			
	SL4	0.626			
	SL5	0.662			
	SMS1	0.792			
School Performance	SMS2	0.513	0.827	0.898	0.747
	SMS4	0.746			
	SMS5	0.773			
	SP1	0.776			
	SP3	0.912			
	SP4	0.899			

This research has also examined the correlation among variables that is known as discriminant validity. The statistics show that the values of Heterotrait Monotrait (HTMT) ratios are not higher than 0.85. These values show that no high correlation among variables. These values are highlighted in Table 2.

Table 2

Discriminant validity

	CSEL	CSSL	SL	SMS	SP
CSEL					
CSSL	0.747				
SL	0.702	0.658			
SMS	0.715	0.726	0.607		
SP	0.829	0.731	0.742	0.700	

This study next examined the variance inflation factor (VIF) for School Performance (SP) to determine the multicollinearity issue in the data. The values of VIF are not less than 0.5 which means no issue of multicollinearity exist with the Dependent variable. These values are mentioned in Table 3.

Table 3

Variance inflation factor (VIF)

	SP
CSEL	2.022
CSSL	1.830
SL	1.631
SMS	1.621

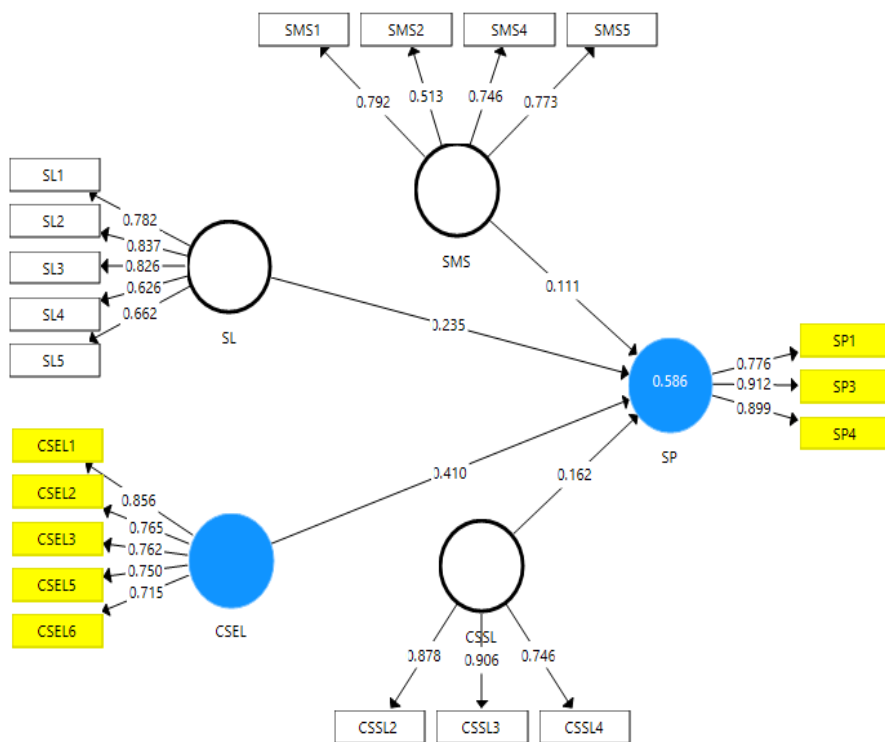

Figure 3: Measurement model assessment

This study has used the path analysis to examine the nexus among the variables. The figures have been shown that communication style of education leadership (CSES), communication style of school leadership (CSSL), school leadership (SL) and school management system (SMS) have positive and significant association with school performance (SP). These values are mentioned in Table 4.

Table 4

Path analysis

Relationships	Beta	S.D.	T Statistics	P Values	L.L.	U.L.
CSEL -> SP	0.41	0.04	9.94	0.00	0.31	0.48
CSSL -> SP	0.16	0.04	4.44	0.00	0.08	0.23
SL -> SP	0.24	0.04	6.66	0.00	0.17	0.31
SMS -> SP	0.11	0.03	3.40	0.00	0.06	0.19

Finally, the present study has shown the R square value that show 58.6 percent variations in school performance are due to the selected predictors such as communication style of education leadership (CSES), communication style of school leadership (CSSL), school leadership (SL) and school management system (SMS). These values are shown in Table 5.

Table 5

R square

	R Square	R Square Adjusted
SP	0.586	0.584

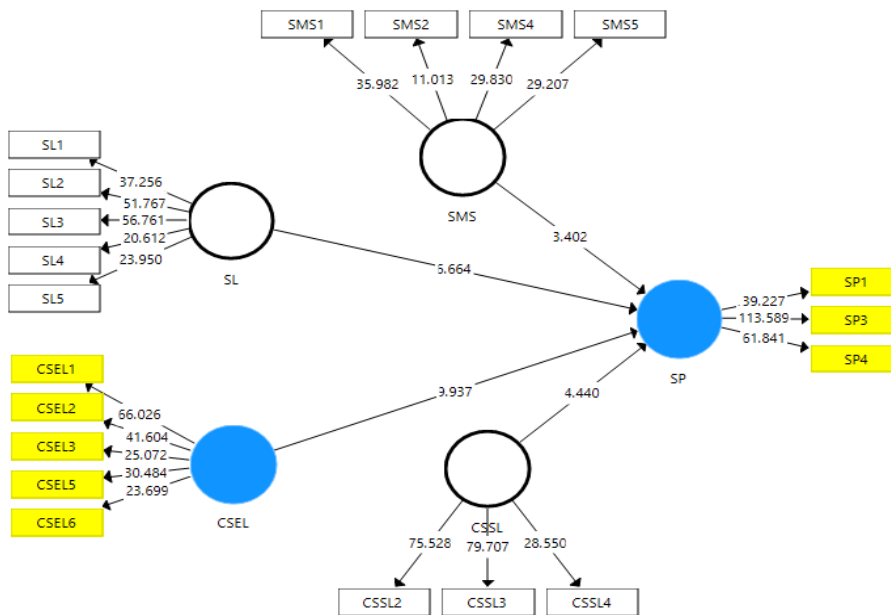

Figure 4: Structural model assessment

Discussion, Conclusion and Recommendations

The results of the present study have revealed that communication style of education leadership (CSES) has positive and significant association with school performance (SP). These findings show that if the leadership of the education institutions is used the effective style of communication that it will lead in the market and enhance the educational sector performance. These outcomes are in line with the results of the Sezer and Uzun (2020) who also investigated the positive association among communication style of education leadership and school performance. In addition, the results also exposed that school leadership (SL) also has positive association with school performance (SP). These outcomes have shown that the recruitment and appointment of school heads was conducted in the light of professional requirements and prescribed education levels of the proposed position. Educational qualification and professionalism were the major requirements in recruitment process. This is consistent with Ricardianto, Ikhsan, Setiawati, and Gugat (2020) who notes that education leadership is one of the foundations of national growth because a good education system will not harbor corruption, since it leads to mistrust, and hinders the development of a nation. In this regard, school head teachers should be appointed based on a competent recruitment system, which takes development seriously. It was also observed during the course of the study that there existed a complementary relationship, a form of guided leadership and good communication, with all the education stakeholders including teachers, parents, students, the public and the government. This is in line with shifting education leadership paradigm and the perspective of good governance, wherein the leader should be a responsible head, who is intellectually and morally upright, who can control emotions and remain physically steady. I. v. E. Jones and Lasthuizen (2018) observe a similar phenomenon and asserts that performance is reflected in building trust, engaging in one's culture, being determined to face social dominance and social justice, and improving instructional practices and engaging all community stakeholders.

The results also shown that the communication style of school leadership (CSSL) has also positive nexus with the school performance. The results exposed that good communication process always reflects a good relationship with the heads and the other stakeholders. Community engagement influences leadership communication patterns, which is a form of relationship or a pattern of relationship among cooperating individuals. These outcomes are matched with the study results of Lumbanraja, Lubis, and Siahaan (2018) who found several challenges faced by school leadership in implementing a focused educational development as well as in planning a sustainable quality improvement education program. These challenges can be successfully resolved effectively through improved communication. Respondents of the study agreed with the view that an inspiring leader should know how to communicate with others. During working hours, he inspires, encourages and motivates others through his polite instructions, respectful communication, trying to always create awareness among the staff through training which enhances the competences of the teachers.

The study revealed that people prefer auditory sounds while listening to instructions and delegation at work. Through a clear, precise, and polite articulation style, leaders communicate with their staff and tend to take a keen look at those who are more attentive during meetings and discussions. A good articulation helps teachers and heads of department to be more focused during teaching and learning sessions, hence they can

influence classroom management. This is consistent with Ullah, Latif, and Alam (2018) noted that being articulate in communication promotes cooperation among two or more people. This could be seen as the influence of the leadership style of communication on school performance. During field observation, it was found that successful teachers are those who are often delegated to participate in training and also who undertake specialized courses after school as continuing education program. A belief was strongly held by most respondents that school leaders and teachers who are successful and well-equipped with good knowledge are able to deliver good school governance; they also help in the improvement of teaching and academic performance of students. This is consistent with several studies that have focused on the aspects that influence teacher's performance in school and determine their success and achievement. These include teacher's personality, experience, efficacy, education level, attitude, specific practices, and achievements of students who they taught such as the study of Damanik and Aldridge (2017) also confirmed that students learn more from teachers with successful instructional leadership styles. In addition, the study of Xhomara (2018) also matched with this study and found that there was a positive relationship between the teacher's academic qualifications and student's academic achievement. In support of this finding, Massry-Herzallah and Arar (2019) reiterated that teacher's self-efficacy has a positive influence on students' motivation and achievement.

The results also exposed that the school management system (SMS) have positive and significant association with school performance (SP). It was also revealed in this study that among other determinants, a proper school management system is a pre-requisite of students' achievement. In other words, the school resources, its building, infrastructure, and facilities contribute greatly to the success and performance of both the staff and students in academics. Since leadership is a key element in development and growth, head teachers should be given freedom of decision making, which in turn will improve school performance. This is in line with Truong and Hallinger (2017) whose arguments have already been accepted earlier in this study, that of the building trust in people, engaging in their culture, facing social dominance and social justice, in order to improve instructional practices.

Conclusion

In Medan, just like other parts of the country, school systems have established a learning model where students learn in groups-- by engaging everyone in a given group. The students tend to learn from peer to peer, a theme or topic is chosen, then rules are set according to age, physical space or environment, each activity directed toward learning a particular topic. The school system consists of curriculum, school culture, school environment, and a model of learning. Shengnan and Hallinger (2021) argue to unite all these aspects in order to ensure a successful or effective leadership to reflect in head teachers.

Head teachers are caretakers of schools; hence, they have a professional management obligation to perform. They are responsible for what takes place in the school environment. In government schools, head teachers protect government's interests. The quality of a headmaster's management styles must match with various aspects of school life such as curriculum, discipline, cultural climate of the school, and students' delinquent behavior. Every headmaster in Medan, Indonesia is facing the challenge of

acquiring such leadership styles that can determine school performance. Having accomplished this, there would be a focused educational development, and sustainable improvement in the quality of education in Indonesia.

Limitations and Future Directions

This study has some limitations that would be helpful future studies who wants to examine this area in future. This study has taken only four predictors such as communication style of education leadership (CSES), communication style of school leadership (CSSL), school leadership (SL) and school management system (SMS) and ignore the other important factors that could also affect the school performance. Thus, this study has recommended to the future studies that they should add other factors that influence the school performance. In addition, this study has ignored the mediation and moderation role in the framework that are also the important factors to examine the school performance. Therefore, this study suggested to the upcoming studies that they should add mediation and moderation in their analysis while investigating this area in future.

References

- Al-Husseini, S., El Beltagi, I., & Moizer, J. (2019). Transformational leadership and innovation: the mediating role of knowledge sharing amongst higher education faculty. *International Journal of Leadership in Education*, 5, 1-24. doi: <https://doi.org/10.1080/13603124.2019.1588381>
- Al-Sada, M., Al-Esmael, B., & Faisal, M. N. (2017). Influence of organizational culture and leadership style on employee satisfaction, commitment and motivation in the educational sector in Qatar. *EuroMed Journal of Business*, 12(2), 163-188. doi: <https://doi.org/10.1108/EMJB-02-2016-0003>
- Aldhaeri, A. (2017). Cultural intelligence and leadership style in the education sector. *International Journal of Educational Management*, 31(6), 718-735. doi: <https://doi.org/10.1108/IJEM-05-2016-0093>
- Anderson, M. (2017). Transformational leadership in education: A review of existing literature. *International Social Science Review*, 93(1), 4-11.
- Arar, K., & Nasra, M. A. (2019). Leadership style, occupational perception and organizational citizenship behavior in the Arab education system in Israel. *Journal of Educational Administration*, 57(1), 85-100. doi: <https://doi.org/10.1108/JEA-08-2017-0094>
- Courtney, S. J. (2018). Privatising educational leadership through technology in the Trumpian era. *Journal of Educational Administration and History*, 50(1), 23-31. doi: <https://doi.org/10.1080/00220620.2017.1395826>
- Dalati, S., Raudeliūnienė, J., & Davidavičienė, V. (2017). Sustainable leadership, organizational trust on job satisfaction: empirical evidence from higher education institutions in Syria. *Business, Management and Economics Engineering*, 15(1), 14-27.
- Damanik, E., & Aldridge, J. (2017). Transformational leadership and its impact on school climate and teachers' self-efficacy in Indonesian high schools. *Journal of School Leadership*, 27(2), 269-296. doi: <https://doi.org/10.1177/105268461702700205>

- Dartey-Baah, K., & Mekpor, B. (2017). Emotional Intelligence: Does Leadership Style Matter? Employees Perception in Ghana's Banking Sector. *International Journal of Business*, 22(1), 41-54.
- Dopson, S., Ferlie, E., McGivern, G., Fischer, M. D., Mitra, M., Ledger, J., & Behrens, S. (2019). Leadership development in Higher Education: A literature review and implications for programme redesign. *Higher Education Quarterly*, 73(2), 218-234. doi: <https://doi.org/10.1111/hequ.12194>
- Elbaz, A. M., & Haddoud, M. Y. (2017). The role of wisdom leadership in increasing job performance: Evidence from the Egyptian tourism sector. *Tourism Management*, 63, 66-76. doi: <https://doi.org/10.1016/j.tourman.2017.06.008>
- Eliyana, A., & Ma'arif, S. (2019). Job satisfaction and organizational commitment effect in the transformational leadership towards employee performance. *European Research on Management and Business Economics*, 25(3), 144-150. doi: <https://doi.org/10.1016/j.iedeen.2019.05.001>
- Elrehail, H. (2018). The relationship among leadership, innovation and knowledge sharing: A guidance for analysis. *Data in brief*, 19, 128-133. doi: <https://doi.org/10.1016/j.dib.2018.04.138>
- Elrehail, H., Emeagwali, O. L., Alsaad, A., & Alzghoul, A. (2018). The impact of transformational and authentic leadership on innovation in higher education: the contingent role of knowledge sharing. *Telematics and Informatics*, 35(1), 55-67. doi: <https://doi.org/10.1016/j.tele.2017.09.018>
- Firdausy, C. M. (2019). The Influence of Leadership Style on Employees' Performance through Work Motivation at the Public Sector of the Government Bureau in Central Kalimantan, Indonesia. *Journal of Applied Economic Sciences*, 14(2), 15-21.
- Guterres, L., Armanu, A., & Rofiaty, R. (2020). The role of work motivation as a mediator on the influence of education-training and leadership style on employee performance. *Management Science Letters*, 10(7), 1497-1504.
- Hair Jr, J. F., Babin, B. J., & Krey, N. (2017). Covariance-based structural equation modeling in the Journal of Advertising: Review and recommendations. *Journal of Advertising*, 46(1), 163-177. doi: <https://doi.org/10.1080/00913367.2017.1281777>
- Holbert, J., Madhakomala, R., Saparuddin, S., & Timotius, E. (2021). The influence of leadership styles on employees' job satisfaction in public sector organizations in Indonesia. *Management Science Letters*, 11(4), 1393-1398.
- Jones, I. v. E., & Lasthuizen, K. (2018). Building public sector integrity in Indonesia: the role and challenges of ethical leadership. *Asia Pacific Journal of Public Administration*, 40(3), 175-185. doi: <https://doi.org/10.1080/23276665.2018.1515392>
- Jones, S., & Harvey, M. (2017). A distributed leadership change process model for higher education. *Journal of Higher Education Policy and Management*, 39(2), 126-139. doi: <https://doi.org/10.1080/1360080X.2017.1276661>
- Kairys, M. R. (2018). The influence of gender on leadership in education management. *International Journal of Educational Management*, 32(5), 931-941. doi: <https://doi.org/10.1108/IJEM-04-2017-0094>
- Kiran, S., & IkramKayani, A. (2020). Transformational Leadership As Mediating Factor Influencing Conflict Management and Performance of Teaching Faculty at Higher Education Level: A Study in Punjab, Pakistan. *Pakistan Social Sciences Review (PSSR)*, 4(2), 272-284.

- Lukiyanto, K. (2018). Leadership style that effective and capable to increase performance based on informal workers perception (case study on Indonesia construction project). *International Journal of Civil Engineering and Technology*, 9(6), 850-860.
- Lumbanraja, P., Lubis, A. N., & Siahaan, E. (2018). The Influence of Organizational Culture, Individual Characteristics, and Transformational Leadership Style on the Job Satisfaction and Performance of Employees in Indonesia. *Calitatea*, 19(163), 85-93.
- Massry-Herzallah, A., & Arar, K. (2019). Gender, school leadership and teachers' motivations. *International Journal of Educational Management*, 33(6), 1395-1410. doi: <https://doi.org/10.1108/IJEM-02-2019-0054>
- Notanubun, Z. (2020). The Effect of Organizational Citizenship Behavior and Leadership Effectiveness on Public Sectors Organizational Performance: Study in the Department of Education, Youth and Sports in Maluku Province, Indonesia. *Public Organization Review*, 15, 1-18. doi: <https://doi.org/10.1007/s11115-020-00475-4>
- Palupi, A., & Kantun, S. (2019). *Women's leadership style in special education cases in Jember regency: 21st century skills challenges*. Paper presented at the IOP Conference Series: Earth and Environmental Science.
- Ricardianto, P., Ikhsan, R., Setiawati, R., & Gugat, R. (2020). How to improve ship crew's work effectiveness through the leadership style, work life balance and employee engagement in Indonesia national shipping. *Management Science Letters*, 10(2), 399-410.
- Saleem, Z., Batool, S., & Khattak, S. R. (2017). Relationship between Leadership Styles and Organizational Commitment: Moderating Role of Emotional Intelligence and Organizational Support. *Journal of Managerial Sciences*, 11(1), 71-84.
- Sezer, Ş., & Uzun, T. (2020). The relationship between school principals' social-emotional education leadership and teachers' organizational trust and job performance. *International Journal of Leadership in Education*, 24, 1-20. doi: <https://doi.org/10.1080/13603124.2020.1849812>
- Shengnan, L., & Hallinger, P. (2021). Unpacking the effects of culture on school leadership and teacher learning in China. *Educational management administration & leadership*, 49(2), 214-233. doi: <https://doi.org/10.1177/1741143219896042>
- Torlak, N. G., & Kuzey, C. (2019). Leadership, job satisfaction and performance links in private education institutes of Pakistan. *International Journal of Productivity and Performance Management*, 68(2), 276-295. doi: <https://doi.org/10.1108/IJPPM-05-2018-0182>
- Triraharjo, J., Aima, H., & Sutawijaya, A. (2019). The Effect of Servant Leadership and Breakthrough Leadership on Organization Performance with Employee Satisfaction as Intervening Variable at IDX-listed (Indonesia Stock Exchange) Coal Mining Companies in Indonesia. *International Review of Management and Marketing*, 9(3), 166. doi: <https://doi.org/10.32479/irmm.8159>
- Truong, T. D., & Hallinger, P. (2017). Exploring cultural context and school leadership: Conceptualizing an indigenous model of có uy school leadership in Vietnam. *International Journal of Leadership in Education*, 20(5), 539-561. doi: <https://doi.org/10.1080/13603124.2015.1105388>
- Udin, U., Handayani, S., Yuniawan, A., & Rahardja, E. (2019). Leadership styles and communication skills at Indonesian higher education: Patterns, influences, and

- applications for organization. *Organizations and markets in emerging economies*, 10(1), 111-131.
- Ullah, R., Latif, K. F., & Alam, W. (2018). Role of transformational leadership style on employee job performance among high and low ranking institutions of higher education of Khyber Pakhtunkhwa. *City University Research Journal*, 8(2), 168-189.
- Veliu, L., Manxhari, M., Demiri, V., & Jahaj, L. (2017). The influence of leadership styles on employee's performance. *Management (16487974)*, 31(2), 59-69.
- Xhomara, N. (2018). Influence of school leadership style on effective teaching and teacher-student interaction. *Pedagogika*, 132(4), 42-62.
- Yaseen, S., Ali, H. Y., & Asrar-ul-Haq, M. (2018). Impact of organizational culture and leadership style on employee commitment towards change in higher education institutions of Pakistan. *Paradigms*, 12(1), 44-53. doi: DOI: 10.24312/paradigms120107